

OWNERSHIP AND RESPONSIBILITY RELATIVE TO THE SANITARY SEWER COLLECTION SYSTEM

THE MIDDLETOWN SEWER DEPARTMENT

The City of Middletown Water & Sewer Department (Department) owns, operates, maintains, repairs and replaces the sanitary sewer collection system located in its Sanitary Sewer Service Area (See Figure #1).

The Department does not maintain the wye, tee/wye, saddle or chimney portions of the sanitary sewer collection system. (Also see Figure #1)

If the Department, during the course of its activities, determines that the Property Owner's (Owner) sanitary sewer main or lateral and/or any associated appurtenances are in need of maintenance, renewal, replacement or repair, the Department will notify the Owner as to the problem and shall not accept any liability for any subsequent problem or expense arising from said condition.

The Department shall determine the responsibility for maintenance, renewal, replacement or repair of any sanitary sewer main and/or sanitary sewer lateral. The Department shall, at its sole discretion, determine if it will renew, replace or repair any portion of the sanitary sewer collection system

Only employees of the Department or contractors approved by the Department will be allowed to make connections to sanitary sewer mains, sanitary sewer laterals and/or appurtenances.

The Department shall not be responsible for damages to personal property resulting from a sanitary sewer backup or that is caused by the failure of ancillary equipment, not owned by the Department, such as, but not limited to, grinder pumps, pump stations, pretreatment facilities, flow equalization facilities, separators, FOG management equipment, check valves, pressure fit cleanout plugs, and below grade facilities (e.g. toilets, slop sinks, washing machines etc.).

The Department is not responsible for the operation, maintenance, renewal, replacement or repair of any sanitary sewer lateral; including sanitary sewer laterals that provide service under any of the following conditions:

- A sanitary sewer lateral that passes through one building or dwelling unit and serves one or more buildings or dwelling units to the rear.
- A sanitary sewer lateral that serves more than one building or dwelling unit.

THE PROPERTY OWNER

The Owner shall own, operate, maintain, replace and repair any private sanitary sewer main, sanitary sewer lateral and associated appurtenances. The Owner shall maintain the wye, tee/wye, saddle and/or chimney. In the event of a blockage, it is the Owner's responsibility to relieve and/or repair the blockage within three (3) days of its discovery. Failure to do so may result in notification of the Building Department, Health Department and in cases where the blockage results in the release of sewage to the environment the State of Connecticut Department of Energy and Environmental Protection.

The City and the Department have no responsibility or liability with regards to those portions of an Owner's sewage collection system that are deemed to be the property of the Owner, including but not limited to, any sanitary sewer main, sanitary sewer lateral and appurtenance, which are to be owned, operated, maintained, repaired and/or replaced by the Owner.

The Owner shall be responsible for marking out, in accordance with CBYD procedures, any private sanitary sewer main, sanitary sewer lateral and associated appurtenances that are owned, operated, maintained, repaired and replaced by the Owner.

The Owner shall, at their own expense, be responsible for the installation, operation, maintenance, replacement and repair of any ancillary equipment, not owned by the Department, such as, but not limited to, grinder pumps, pump stations, pretreatment facilities, flow-equalization facilities, separators, FOG management equipment etc.

The Owner shall be responsible for ensuring that all discharges that ultimately flow to the public sanitary sewer collection system conform to the parameters set forth in the Regulations of the State of Connecticut.

Renewals, replacements, repairs and/or extensions of private sanitary sewer mains, sanitary sewer laterals, and/or appurtenances shall be made in accordance with Rules and Regulations of the Department. The Owner/Applicant shall be responsible for all costs.

The Owner shall pay any and all bills issued by the Department in accordance with the Schedule of Rates, Charges and Fees.

FIGURE 1
SANITARY SEWER SYSTEM

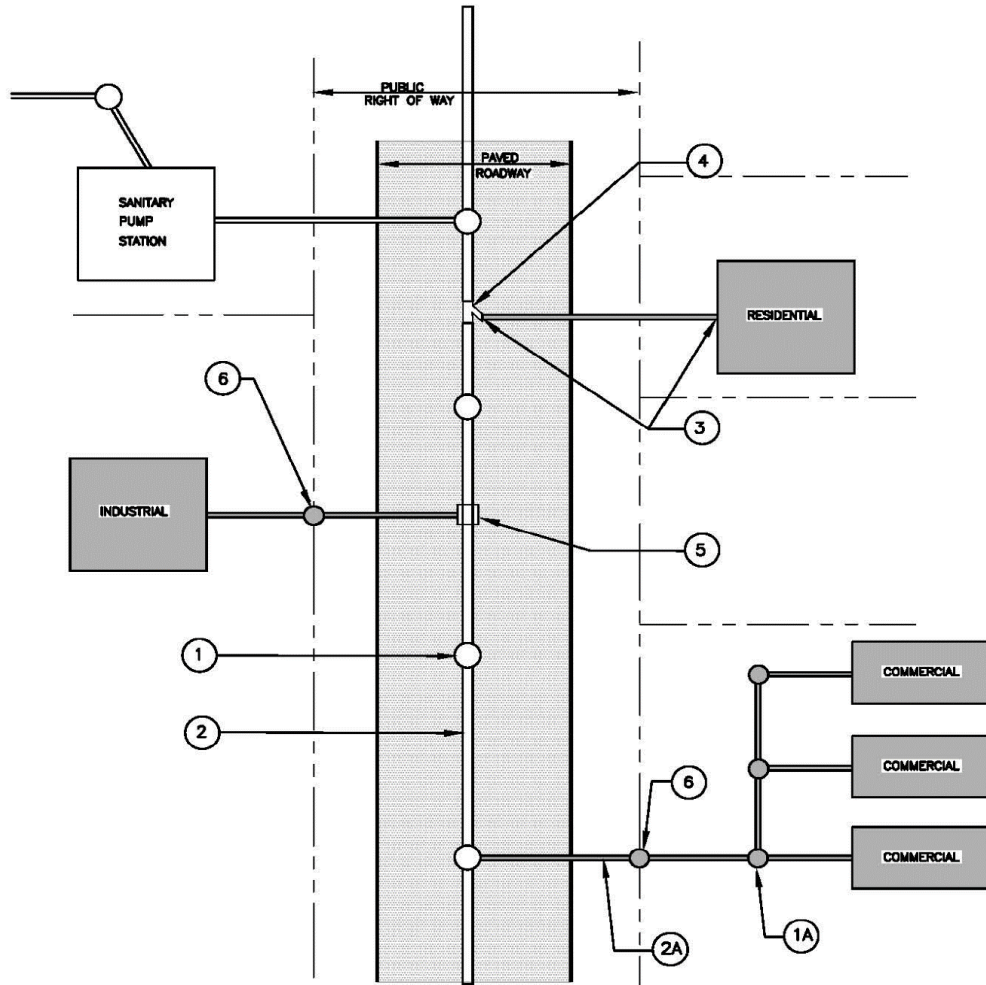

SANITARY SEWER COLLECTION SYSTEM (OWNED, OPERATED, MAINTAINED, REPAIRED, AND REPLACED BY MIDDLETOWN SEWER DEPARTMENT)

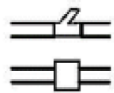

SANITARY SEWER WYE, TEE/WYE, SADDLE, OR CHIMNEY OWNED, OPERATED, REPAIRED, AND REPLACED BY THE MIDDLETOWN SEWER DEPARTMENT (BUT MAINTAINED BY THE OWNER)

--- PROPERTY LINE / R.O.W. LINE

1 SANITARY SEWER MANHOLE (PUBLIC)

1A SANITARY SEWER MANHOLE (PRIVATE)

2 SANITARY SEWER MAIN (PUBLIC)

2A SANITARY SEWER MAIN (PRIVATE)

3 SANITARY BUILDING SEWER LATERAL (PRIVATE)

4 SANITARY SEWER WYE, TEE/WYE, SADDLE)

5 SANITARY SEWER CHIMNEY

6 SANITARY SEWER MANHOLE FOR INSPECTIONS (PRIVATE)

FIGURE 2
SANITARY SEWER LATERAL

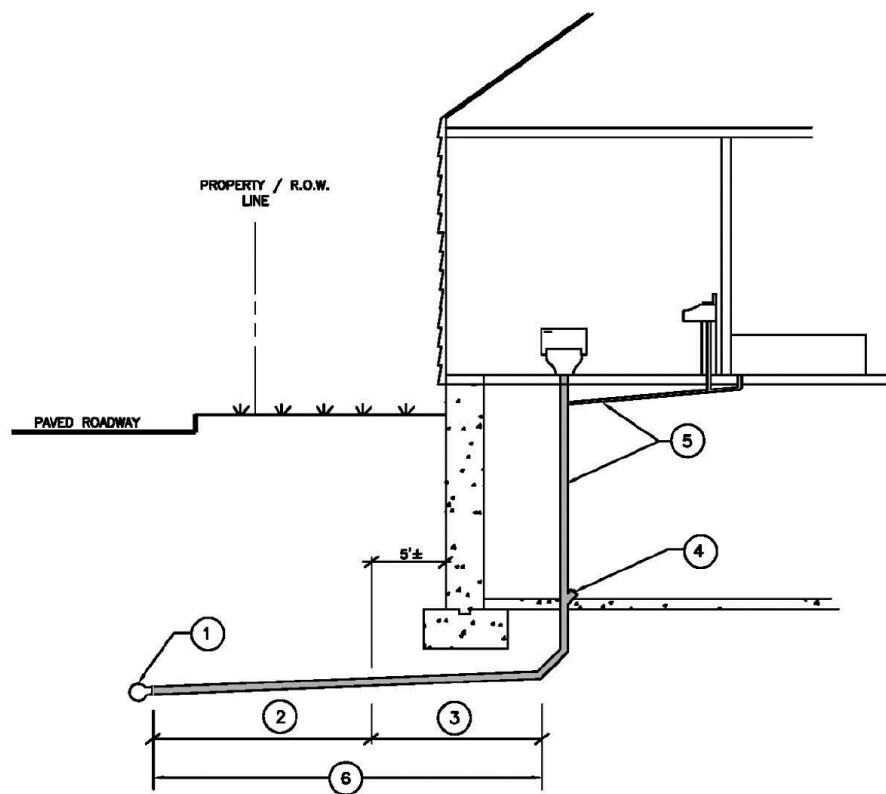

NOTE: THE SHADED PORTIONS OF THE SYSTEM CONSTITUTE THE SANITARY SEWER LATERAL AND THE DOMESTIC WASTEWATER SYSTEM AND ARE OWNED, OPERATED, MAINTAINED, REPAIRED, AND REPLACED BY THE OWNER

- | | |
|-----------------------|-----------------------------------|
| ① SANITARY SEWER MAIN | ④ CLEANOUT |
| ② BUILDING SEWER | ⑤ DOMESTIC WASTEWATER SYSTEM |
| ③ BUILDING DRAIN | ⑥ SANITARY BUILDING SEWER LATERAL |